



## N Series Heavy Duty Diesel Forklift Truck

5.0-10.0 Ton Diesel Forklift





## Heavy Duty Diesel Forklift 5.0-10.0 Ton

UN's 5.0-10.0 ton heavy duty diesel forklift trucks are designed for high performance, maximum efficiency and lowest possible operating cost. Its robust components enable the forklift to operate over rough terrain with excellent maneuverability.

### Reliability



Powerful engine: 6-cylinder engine with low noise and minimal vibration. The high torque and high output at low rpm guarantee's high performance.



Excellent cooling system: Advanced cooling technology matched with a large-capacity water tank and large exhaust window to improve cooling channel effectively.



Strengthened and tough axles & large turning angle: Makes it efficient with flexible handling and steering.



The accumulator in the brake system generates compression energy. The hydraulic energy is distributed immediately to the brake system resulting in prompt break response.

## Safety



High intensity rollover protection structure (ROPS) guarantees the operator's safety.



Heavy duty welded mast: Wide design ensures excellent forward visibility, improving work efficiency and safety.





## Comfort



Adjustable seat, adjustable steering wheel, large foot space and wide operation space provides maximum comfort.

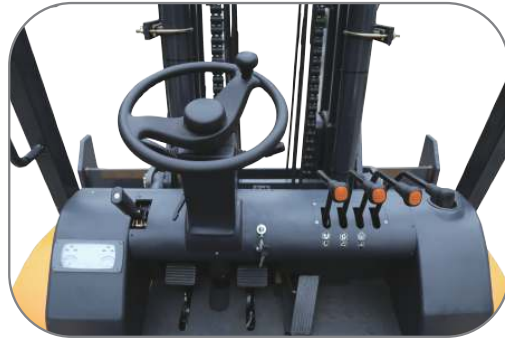

Intelligent instrument panel includes; fuel level, hour meter, water temperature, engine oil indicator, charger indicator, preheating indicator, oil filter alarm, forward, reverse and neutral direction indicators.



Large, anti skid tyres.

## Easy Service and Maintenance



Wide opening engine hood for easy servicing.



Optimal internal layout for improved serviceability.



Rear cover accessible to allow the radiator to be cleaned.

# Diesel Forklift 5.0-7.0T

## MAIN SPECIFICATIONS

General	1	Model	FD50T-NJH1	FD60T-NJH1	FD70T-NJH1	FD50T-NJB3	FD60T-NJB3	FD70T-NJB3	
	2	Power Type		Diesel					
3	Rated Load Capacity	Q(kg)	5000	6000	7000	5000	6000	7000	
4	Load Centre	C(mm)	600						
Characteristic & Dimension	5	Rated Lift Height	H3(mm) 3000						
	6	Free Lift Height	H2(mm) 152						
	7	Fork Size (L×W×T)	mm 1220×150×60		1220×150×65		1220×150×60		1220×150×65
	8	Mast Tilt Angle (F/R, α°/β°)	deg 6°/12°						
	9	Fork Overhang (Wheel Center to Fork Face)	X1(mm) 585						
	10	Rear Overhang	X2(mm) 640		720		640		720
	11	Ground Clearance (Bottom of Mast)	H7(mm) 200						
	12	Length to Face of Fork (Without Fork)	L1(mm) 3510		3590		3510		3590
	13	Overall Width	B1(mm) 1995						
	14	Mast Lowered Height	H1(mm) 2515		2615		2515		2615
	15	Mast Extended Height (With Backrest)	H4(mm) 4437						
	16	Overhead Guard Height	H5(mm) 2415						
	17	Turning Radius (Outside)	Wa(mm) 3280		3360		3280		3360
	18	Wheelbase	Y(mm) 2250						
	19	Front Tread	mm 1470						
	20	Rear Tread	mm 1700						
Performance	21	Min. Aisle width for pallets	Ast(mm) 5285		5365		5285		5365
	22	Travel Speed (No Load)	km/h 20						
	23	Lifting Speed (Full Load)	mm/sec 400		330		500		460
	24	Max. Gradeability (Full Load)	% 32		27		24		35
Weight	25	Max. Drawbar Pull (Full Load)	KN 53		52		53		52
	26	Total Weight	kg 7980		8640		9350		7980
	27	Front Axle Weight Distribution (Full Load/No Load)	kg 11660/4010		13050/3880		14570/3860		11660/4010
Power & Transmission	28	Rear Axle Weight Distribution (Full Load/No Load)	kg 1320/3970		1590/4760		1780/5490		1320/3970
	29	Battery	V/Ah 24/90						
	30	Engine Model	6102BG6			A-6BG1QC			
	31	Engine Manufacturer	CHAOCHAI			ISUZU			
	32	Rated Output / r.p.m.	kw 80.9/2500			82/2000			
	33	Rated Torque / r.p.m.	N·m 353/1650			416/1400 – 1600			
	34	No. of Cylinder	6						
	35	Bore x Stroke	102×118			105×125			
	36	Transmission Type	Powershift						
	37	Transmission Stage (FWD/RVS)	2/2						
38	Operating Pressure (For Attachments)	Mpa 17							

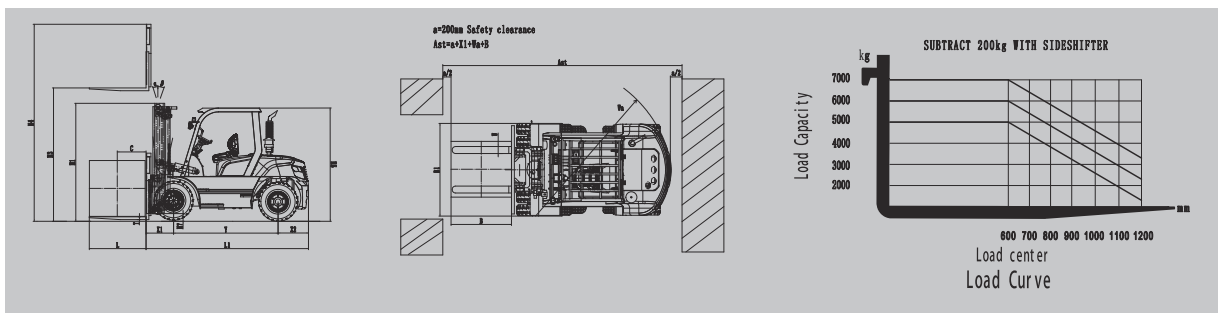



## Diesel Forklift 8.0-10.0T

### MAIN SPECIFICATIONS

		FD80T-NGH1	FD100T-NJH1	FD80T-NJB3	FD100T-NJB3	FD80T-NJR2	FD100T-NJR2	
General	1 Model							
	2 Power Type	Diesel						
	3 Rated Load Capacity	Q(kg)	8000	10000	8000	10000	8000	10000
	4 Load Centre	C(mm)	600					
Characteristic & Dimension	5 Rated Lift Height	H3(mm)	3000					
	6 Free Lift Height	H2(mm)	120					
	7 Fork Size (L×W×T)	mm	1220×175×75	1220×175×80	1220×175×75	1220×175×80	1220×175×75	1220×175×80
	8 Mast Tilt Angle (F/R, α°/β°)	deg	6°/12°					
	9 Fork Overhang (Wheel Center to Fork Face)	X1(mm)	721					
	10 Rear Overhang	X2(mm)	760					
	11 Ground Clearance (Bottom of Mast)	H7(mm)	250					
	12 Length to Face of Fork (Without Fork)	L1(mm)	4040	4270	4040	4270	4040	4270
	13 Overall Width	B1(mm)	2165					
	14 Mast Lowered Height	H1(mm)	2695	2845	2695	2845	2695	2845
	15 Mast Extended Height (With Backrest)	H4(mm)	4020	4260	4020	4260	4020	4260
	16 Side Shift	X(mm)	340-2000	440-2140	340-2000	440-2140	340-2000	440-2140
	17 Overhead Guard Height	H5(mm)	2520	2540	2520	2540	2520	2540
	18 Wheelbase	Y(mm)	2500	2800	2500	2800	2500	2800
	19 Turning Radius (Outside)	Wa(mm)	3700	3900	3700	3900	3700	3900
	20 Min.Aisle width for pallets	Ast(mm)	5845	6045	5845	6045	5845	6045
Performance	21 Travel Speed (No Load)	km/h	20					
	22 Lifting Speed (Full Load)	mm/sec	380	310	380	310	380	310
	23 Lowering Speed (Full Load)	mm/sec	480	500	480	500	480	500
	24 Max.Drawbar Pull (Full Load)	KN	58	57	58	57	58	57
	25 Max.Gradeability (Full Load)	%	≤20					
Weight	26 Total Weight	kg	11850	12900	11850	12900	11850	12900
	27 Front Axle Weight Distribution (Full Load/No Load)	kg	17800/4740	20610/5660	17800/4740	20610/5660	17800/4740	20610/5660
	28 Rear Axle Weight Distribution (Full Load/No Load)	kg	2050/7110	2290/8240	2050/7110	2290/8240	2050/7110	2290/8240
Power & Transmission	29 Battery	V/Ah	24/90					
	30 Engine Model		6102BG6		A-6BG1QC		QSB4.5 (EU/III & EPA/III)	
	31 Engine Manufacturer		CHAOCHAI		ISUZUJ		CUMMINS	
	32 Rated Output / r.p.m.	kw	80.9/2500		82/2000		82/2200	
	33 Rated Torque / r.p.m.	N·m	353/1650		416/1400-1600		489/1500	
	34 No.of Cylinder		6				4	
	35 Bore x Stroke		102×118		105×125		107×124	
	36 Transmission Type		Powershift					
	37 Transmission Stage (FWD/RVS)		2/2					
	38 Operating Pressure (For Attachments)	Mpa	17					

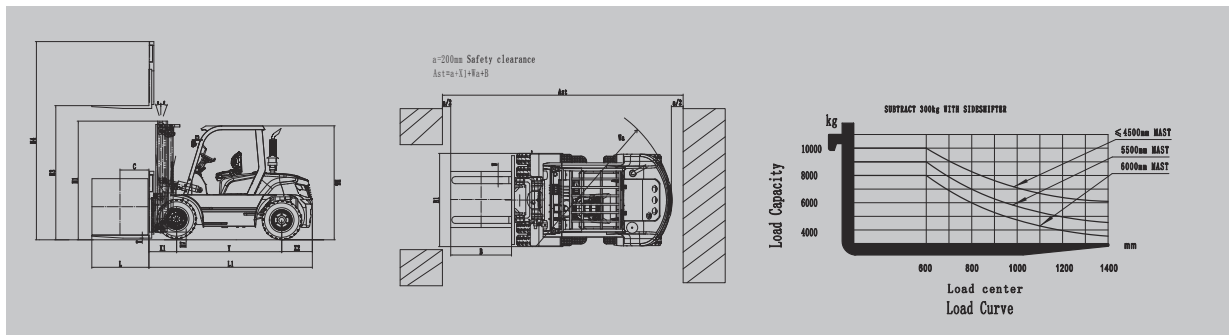

### 5.0-7.0 TON MAST SPECIFICATIONS & RATED CAPACITIES

Mast Type	Mast Name	Max. Fork Height (mm)	Load Capacity (kg) Load Center 600mm			Overall Height (mm)						Free Lift (mm)				Tilt Angle	Total Weight (kg)		
						Extended			Lowered			Extended			Without Backrest				
			Lowered	Without Backrest	With Backrest	Lowered	Without Backrest	With Backrest	Without Backrest	With Bracket	Without Backrest	With Bracket	Without Backrest	With Bracket					
			5.0t	6.0t	7.0t	5.0t/6.0t			7.0t			5.0t/6.0t		7.0t					
2-Stage Wide View Mast	M300	3000	5000	6000	7000	2515	3967	4437	2615	4067	4437	152	152	6-12	7980	8640	9350		
	M330	3300	5000	6000	7000	2665	4267	4737	2765	4367	4737	152	152	6-12	8025	8685	9395		
	M350	3500	5000	6000	7000	2765	4467	4937	2865	4567	4937	152	152	6-12	8055	8715	9425		
	M370	3700	5000	6000	7000	2890	4667	5137	2990	4767	5187	152	152	6-12	8095	8750	9460		
	M400	4000	5000	6000	7000	3065	4967	5437	3165	5067	5437	152	152	6-12	8145	8805	9515		
	M430	4300	5000	6000	7000	3165	5267	5737	3265	5367	5737	152	152	6-12	8175	8835	9545		
	M450	4500	5000	6000	7000	3315	5467	5937	3415	5567	5937	152	152	6-12	8315	8975	9685		
	M470	4700	5000	6000	7000	3440	5667	6137	3540	5767	6187	152	152	6-6	8350	9010	9720		
	M500	5000	5000	6000	7000	3565	5967	6437	3665	6067	6437	152	152	6-6	8390	9050	9760		
	M550	5500	4750	5700	6600	3865	6467	6937	3965	6567	6937	152	152	3-6	8570	9230	9940		
3-Stage Full Free Wide View Mast	M600	6000	4400	5400	6400	4115	6967	7437	4215	7067	7437	152	152	3-6	8645	9305	10015		
	TFM400	4000	5000	6000	7000	2510	5112	5437	2610	5112	5437	1378	1065	1378	1165	6-6	8540	9200	9895
	TFM430	4300	4500	5600	6500	2625	5412	5737	2725	5412	5737	1494	1180	1494	1280	6-6	8560	9220	9950
	TFM450	4500	4500	5600	6000	2675	5612	5937	2775	5612	5937	1544	1230	1544	1330	6-6	8580	9240	9970
	TFM470	4700	4500	5600	6000	2775	5812	6137	2875	5812	6137	1644	1330	1644	1430	6-6	8625	9285	10015
	TFM500	5000	4500	5600	6000	2840	6112	6437	2940	6112	6437	1708	1395	1708	1495	3-6	8720	9380	10110
	TFM550	5500	4200	5300	6000	3005	6612	6937	3105	6612	6937	1874	1560	1874	1660	3-6	8795	9455	10185
TFM600	6000	4000	5000	6000	3220	7112	7437	3320	7112	7437	2044	1775	2044	1875	3-6	8885	9545	10275	

Note: With separated side shifter, load capacity subtract 350kg; With integrated side shifter, load capacity subtract 100kg.  
\*Double front wheels are standard.

### 8.0T MAST SPECIFICATIONS & RATED CAPACITIES

Mast Type	Mast Name	Max. Fork Height (mm)	Load Capacity (kg) Load Center 600mm	Overall Height (mm)		Free Lift (mm)	Tilt Angle (F/R)	Total Weight (kg)
				Lowered	Extended			
				8.0t	8.0t	8.0t		
2-Stage Wide View Mast	M300	3000	8000	2695	4130	120	6-12	11850
	M350	3500	8000	2945	4630	120	6-12	11945
	M400	4000	8000	3245	5180	120	6-12	12190
	M450	4500	8000	3495	5680	120	6-12	12280
	M500	5000	7750	3745	6180	120	6-6	12375
	M550	5500	7400	4045	6730	120	3-6	12620
	M600	6000	7000	4295	7230	120	3-6	12715

### 10.0T MAST SPECIFICATIONS & RATED CAPACITIES

Mast Type	Mast Name	Max. Fork Height (mm)	Load Capacity (kg) Load Center 600mm	Overall Height (mm)		Free Lift (mm)	Tilt Angle (F/R)	Total Weight (kg)
				Lowered	Extended			
				10.0t	10.0t	10.0t		
2-Stage Wide View Mast	M250	2500	10000	2595	3785	140	6-12	12805
	M300	3000		2845	4285	140	6-12	12900
	M330	3300		2995	4585	140	6-12	12955
	M350	3500		3095	4785	140	6-12	12995
	M400	4000		3395	5320	140	6-12	13240
	M450	4500		3645	5820	140	6-6	13330
	M470	4700		3770	6070	140	6-6	13380
	M500	5000		3895	6320	140	6-6	13425
	M550	5500		4195	6870	140	3-6	13670
	M600	6000		4445	7370	140	3-6	13765
3-Stage Full Free Wide View Mast	TFM400	4000	8000	2695	5335	1325	6-12	13545
	TFM430	4300	7800	2815	5695	1445	6-12	13610
	TFM450	4500	7800	2865	5845	1495	6-12	13650
	TFM470	4700	7500	2965	6145	1595	6-6	13710
	TFM500	5000	7000	3030	6340	1660	6-6	13735
	TFM550	5500	6000	3220	6760	1850	3-6	13860
TFM600	6000	6000	3420	7360	2050	3-6	14115	

Note: With integrated side shifter, load capacity subtract 200kg.  
\*Double front wheels and pin type forks are standard.



 [www.unforklifts.com.au](http://www.unforklifts.com.au)

