

HOEFLOM TC1 TRACKED CARRIER

HOEFLOM CARRIERS



The TC1 carrier is the solution for horizontal transport of long, heavy construction material and equipment at a project site.

The carrier is compact and just 80 cm wide, and material can be placed on it in the length or width. The radio remote controlled carrier is perfect for transporting material, such as steel beams, through small access doors and less easily accessible areas.

No more heavy lifting for your personnel. Ergonomic, efficient and safe!

TC1 KEY FEATURES

- Compact, strong and robust
- Precisely manoeuvrable
- Easy to attach load
- Extendible platform
- Silent thanks to electric drive
- Rotating platform

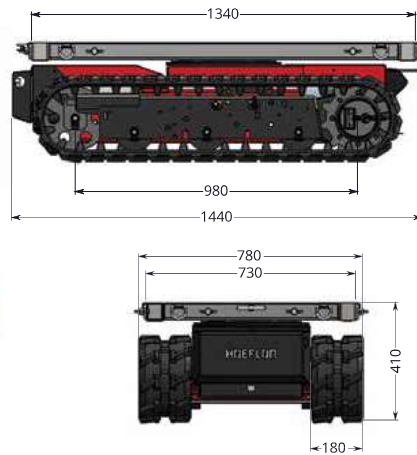

HOEFLON TC1

Standard configuration

Capacity	1,200kg
Net weight	500kg
Dimensions LxWxH	1450 x 800 x 420mm
Drive	electric
Power supply	battery pack
Charger	240 V 50Hz
Charging time	13 hrs
Ground pressure, driving (approx)	14.7 kN/m ²
Max. speed	2.2km/h
Speed controller	proportional operation
Max. slope angle	25°
Max. tilt angle	20°
Load platform LxW	1340 x 730mm
Type platform	rotating

Accessories/Options

Tracks	non-marking
External power supply	240 V

