

**liftsmart**

**LS15**

Straddle Leg  
Electric Stackers



## LS15

### Straddle Leg Electric Stackers

The Liftsmart LS15 series offers a strong, robust mast with an extension height of up to 3.3m. The external charger has also been designed to operate with greater reliability.

Thanks to Liftsmart's sleep model and low battery voltage alarm function, energy consumption is significantly reduced.

- ✓ Mid-driving unit with 3 point standing chassis design, reducing the risk of the drive wheel slipping or losing traction
- ✓ Ergonomically designed and built handle for comfortable operation
- ✓ Secure dustproof design improves the life of the machine
- ✓ Intelligent and modular control system ensures stable operation when lifting, lowering, moving and braking
- ✓ Upper mounted handle designed for easier operation and steering
- ✓ Wide mast provides high visibility, making lifting more precise and increasing safety
- ✓ With the flick of a switch, automatically limit maximum travel speed when the load is higher than 0.7m

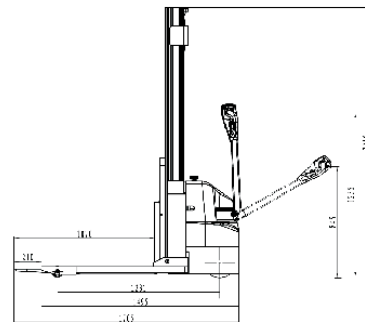
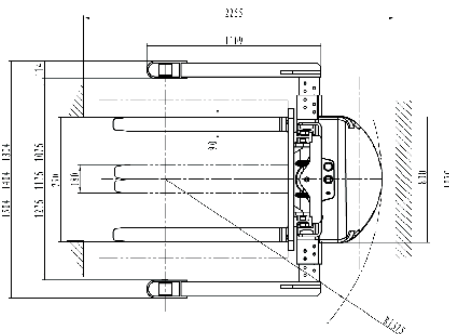



## Specifications

Model		LS15	
<b>Characteristics</b>			
1.1	Operator Type		Walkie
1.2	Capacity	kg	1500
1.3	Load Centre	mm	600
1.4	Wheel Base	mm	1231
<b>Weight</b>			
2.1	Service Weight (Incl. Battery)	kg	510 / 580 / 610 / 640
<b>Wheels</b>			
3.1	Tyre Type		PU
3.2	Tyre Size, Drive Wheels	mm	Φ 230 x 70
3.3	Tyre Size, Load Wheels	mm	Φ 84 x 70
3.4	Tyre Size, Balance Wheels	mm	Φ 115 x 55
3.5	Wheels, Numbers (x=drive wheel)		1 x + 2
<b>Dimensions</b>			
4.1	Height, Mast Lowered	mm	2160 / 1795 / 2045 / 2195
4.2	Lift Height	mm	1600 / 2500 / 3000 / 3300 / 3500 / 3600
4.3	Height, Mast Extended	mm	2150 / 3005 / 3505 / 3805 / 4005 / 4105
4.4	Height of tiller arm, Min/Max	mm	910 / 1230
4.5	Fork Height, Lowered	mm	85
4.6	Overall Length	mm	1705
4.7	Overall Width	mm	-
4.8	Fork Dimension	mm	1070 x 100 x 30
4.9	Outside Fork Width	mm	200~800
4.10	Ground Clearance	mm	30
4.11	AST,1000X1200 pallet crosswaysmm		2255
4.12	AST,800X1200 pallet crosswaysmm		2180
4.13	Outer Turning Radius	mm	1375
4.14	Straddle leg OD	mm	1280 / 1480
4.15	Straddle leg ID	mm	1180 / 1380
<b>Performance</b>			
5.1	Travel Speed, Laden/Unladen	km/h	5.0 / 5.5
5.2	Lifting Speed, Laden/Unladen	m/s	0.20 / 0.21
5.3	Lower Speed, Laden/Unladen	m/s	0.12 / 0.11
5.4	Max Gradeability, Laden/Unladen	%	3.0 / 10.0
<b>Drive</b>			
6.1	Drive Motor Rating S2 60Min	kw	1.10DC / AC
6.2	Lifting Motor Rating S3 15%	kw	2.20 DC
6.3	Battery Voltage/Capacity(5h)	V/Ah	24 / 80
<b>Others</b>			
7.1	Controller		PG
7.2	Service Brake		Regenerate
7.3	Parking Brake		Electromagnetic

## Load Chart

LS15	
Lift Height (mm)	Actual Capacity (kg)
0	1500
3000	1500
3500	1000

## Branches

### VICTORIA

#### Melbourne - Springvale (Head Office)

📍 1574 Centre Rd  
Springvale, VIC, 3171  
☎ [03] 9547 8000

#### Melbourne - Truganina

📍 501 Robinsons Rd  
Truganina, VIC, 3029  
☎ [03] 9394 4000

### NEW SOUTH WALES

#### Sydney (State Office)

📍 219 Newton Rd  
Wetherill Park, NSW, 2164  
☎ [02] 8788 1777

#### Port Kembla

📍 20-26 Flinders Street  
Port Kembla, NSW, 2505  
☎ 13 22 54

### QUEENSLAND

#### Brisbane (State Office)

📍 11 Lombank Street  
Acacia Ridge, QLD, 4110  
☎ [07] 3373 5111

#### Rockhampton

📍 62 Glenmore Road  
Park Avenue, Rockhampton  
QLD 4701  
☎ [07] 4922 8874

#### Townsville

📍 39 Duckworth Street  
Garbutt, QLD, 4814  
☎ [07] 4778 2000

### SOUTH AUSTRALIA

#### Adelaide (State Office)

📍 18-22 Churchill Rd. Nth.  
Dry Creek, SA, 5094  
☎ [08] 8360 3444

### WESTERN AUSTRALIA

#### Perth (State Office)

📍 Unit 1, 1-9 Kurnall Road  
Welshpool, WA, 6106  
☎ [08] 9352 9200

#### Karratha

📍 Lot 3873-Pemberton Road  
Karratha, WA, 6714  
☎ 13 22 54

### TASMANIA

#### Spreyton

📍 87a Devonport Road  
Spreyton, TAS, 7310  
☎ [03] 6427 3966

## Service Centres

### VICTORIA

Bendigo  
Warrnambool  
Ballarat  
Shepparton  
Wodonga  
Mildura

### TASMANIA

Hobart  
Launceston  
Burnie

### NEW SOUTH WALES

Albury  
Bathurst  
Central Coast  
Coffs Harbour  
Cowra  
Dubbo  
Forbes  
Griffith  
Newcastle  
Orange  
Parkes  
Queanbeyan  
Tamworth  
Temora  
Young  
West Wyalong  
Wollongong

### QUEENSLAND

Rockhampton  
Mackay  
Cairns  
Gladstone  
Townsville  
Mt Isa  
Toowoomba  
Gold Coast  
Sunshine Coast

### SOUTH AUSTRALIA/NT

Riverland  
Darwin

### WESTERN AUSTRALIA

Bunbury  
Kalgoorlie  
Karratha

