

Technical sheet :

MI-X 80 D



Technical characteristics			Metric
1.1	Manufacturer		Manitou
1.2	Model Name		MI-X 80 D
1.3	Power source		Diesel
1.4	Operator type		Seated
1.5	Max. capacity	Q	8000 kg
1.6	Load centre of gravity	c	600 mm
1.8	Load distance, centre of drive axle to fork	x	705 mm
1.9	Wheelbase	y	2500 mm
Weight			
2.1	Service weight		11790 kg
2.2	Weight on front axle (laden) / rear axle (laden)		17670 kg / 2120 kg
2.3	Weight on front axle (Unladen) / rear axle (Unladen)		4870 kg / 6920 kg
Wheels			
3.1	Tyres type		Pneumatic
3.2	Dimensions of front wheels		9.00-20-14PR
3.3	Dimensions of rear wheels		9.00-20-14PR
3.5	Number of front wheels / rear wheels		4 / 2
3.5.2	Number of drive wheels		4
3.6	Front wheel gauge	b10	1628 mm
3.7	Rear wheel gauge	b11	1700 mm
Dimensions			
4.1	Tilt of Mast Forward (deg) / Backward (deg)	α / β	6 / 12
4.7	Height of overhead guard (cabin)	h6	2580 mm
4.8	Seat height/stand height	h7	1505 mm
4.12	Height of towing bar (coupling height)	h10	505 mm
4.19	Overall length	l1	5395 mm
4.20	Length to face of forks	l2	3895 mm
4.21	Overall width	b1	2165 mm
4.21	Overall width - Single wheels	b1	2165 mm
4.22	Forks section / width / length	s / e / l	75 mm x 160 mm / 1520 mm
4.23	Fork carriage ISO 2328 (class/form) A/B		4A
4.24	Fork carriage width	b3	2040 mm
4.31	Ground clearance below mast	m1	185 mm
4.32	Ground clearance at centre of wheelbase	m2	339 mm
4.34	Aisle width for 800 x 1200 pallet lengthways	Ast	5803 mm
4.36	Internal turning radius (over tyres)	b13	1327 mm
4.35	Turning radius	Wa	3630 mm
Performances			
5.1	Travel speed (laden / unladen)		28 km/h / 32 km/h
5.2	Lifting speed (laden / unladen)		0.43 m/s / 0.46 m/s
5.3	Lowering speed (laden / unladen)		0.45 m/s / 0.36 m/s
5.5	Drawbar pull (Laden / Unladen)		7860 daN / 4500 daN
5.7	Gradeability (laden / unladen)		44 % / 44 %
5.10	Service brake		Hydraulic
Engine			
7.1	Engine brand / model		Cummins / QSB4,5
7.2	Engine power according to ISO 1585		82 kW
7.3	Rated speed		2200 rpm
7.4	Number of cylinders / Capacity of cylinders		4 - 4500 cm ³
7.5	Fuel consumption according to VDI cycle		11.5 l/h
Miscellaneous			
8.2	Working hydraulic pressure for attachments		195 Bar
8.3	Oil flow rate for attachments		180 l/min
8.4	Measured/guaranteed mean noise level at the ear of the operator		< 88 dB(A)

Dimensional drawing

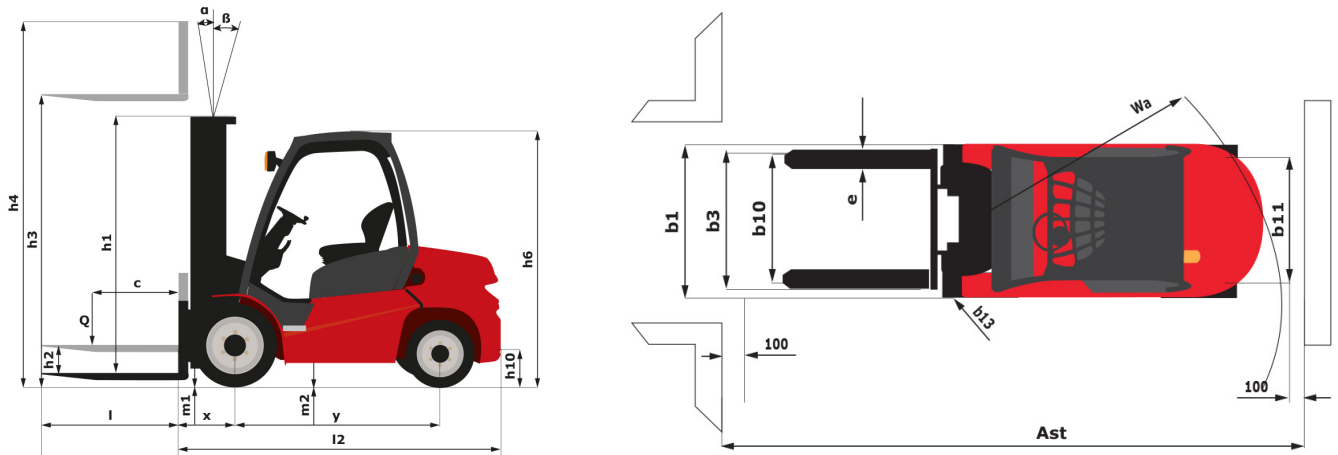

Characteristics of masts and residual capacities

Full Visibility Duplex		FVD 30	FVD 33	FVD 36	FVD 40	FVD 45	FVD 50
h2 - Free lift	mm	200	200	200	200	200	200
h1 - Height mast lowered *	mm	2700	2850	3000	3200	3500	3750
h3 - Lifting Height	mm	3000	3300	3600	4000	4500	5000
h4 - Height mast extended *	mm	4210	4510	4810	5210	5710	6210
α / β - Mast inclination (front / rear)	°	6 / 12	6 / 12	6 / 12	6 / 12	6 / 6	6 / 6
Residual capacity without attachment (Industrial load chart)	kg	8000	8000	8000	8000	8000	8000
Height at max capacity	mm	3000	3300	3600	4000	4500	5000
Height at max capacity Fork positioner + DL	mm	3000	3300	3600	4000	4500	5000
Residual capacity with integrated sideshift (Maximum height & LC = 600 mm)	kg	7600	7600	7600	7600	7600	7600

Free Lift Triplex		FLT 45	FLT 48	FLT 50	FLT 55	FLT 60
h2 - Free lift	mm	1485	1585	1600	1800	1985
h1 - Height mast lowered *	mm	2750	2850	2950	3100	3250
h3 - Lifting Height	mm	4500	4800	5000	5500	6000
h4 - Height mast extended *	mm	5775	6075	6360	6810	7275
α / β - Mast inclination (front / rear)	°	6 / 6	6 / 6	6 / 6	3 / 6	3 / 6
Residual capacity without attachment (Industrial load chart)	kg	7000	7000	6500	6100	5600
Height at max capacity	mm	4500	4800	5000	5500	6000
Height at max capacity Fork positioner + DL	mm	4500	4800	5000	5500	6000
Residual capacity with integrated sideshift (Maximum height & LC = 600 mm)	kg	6600	6600	6100	5700	5200



Siège Social

430 rue de l'Aubinière - 44150 Ancenis Cedex - France

Tel: +33(0)2 40 09 10 11 - Fax: +33 (0)2 40 09 10 97

www.manitou.com



This brochure describes versions and configuration options for Manitou products which may be fitted with different equipment. The equipment described in this brochure may be standard, optional or not available depending on version. Manitou reserves the right to change the specifications shown and described at any time and without prior warning. The manufacturer is not liable for the specifications given. For more information, contact your Manitou dealer. Non-contractual document. Product descriptions may differ from actual products. List of specifications is not comprehensive. The logos and visual identity of the company are the property of Manitou and may not be used without authorisation. All rights reserved. The photos and diagrams contained in this brochure are provided for information only.

MANITOU BF SA - Limited company with board of directors - Share capital: 39,668,399 euros - 857 802 508 RCS Nantes